

REACH UPTM

Mobile Aerial Work Platforms

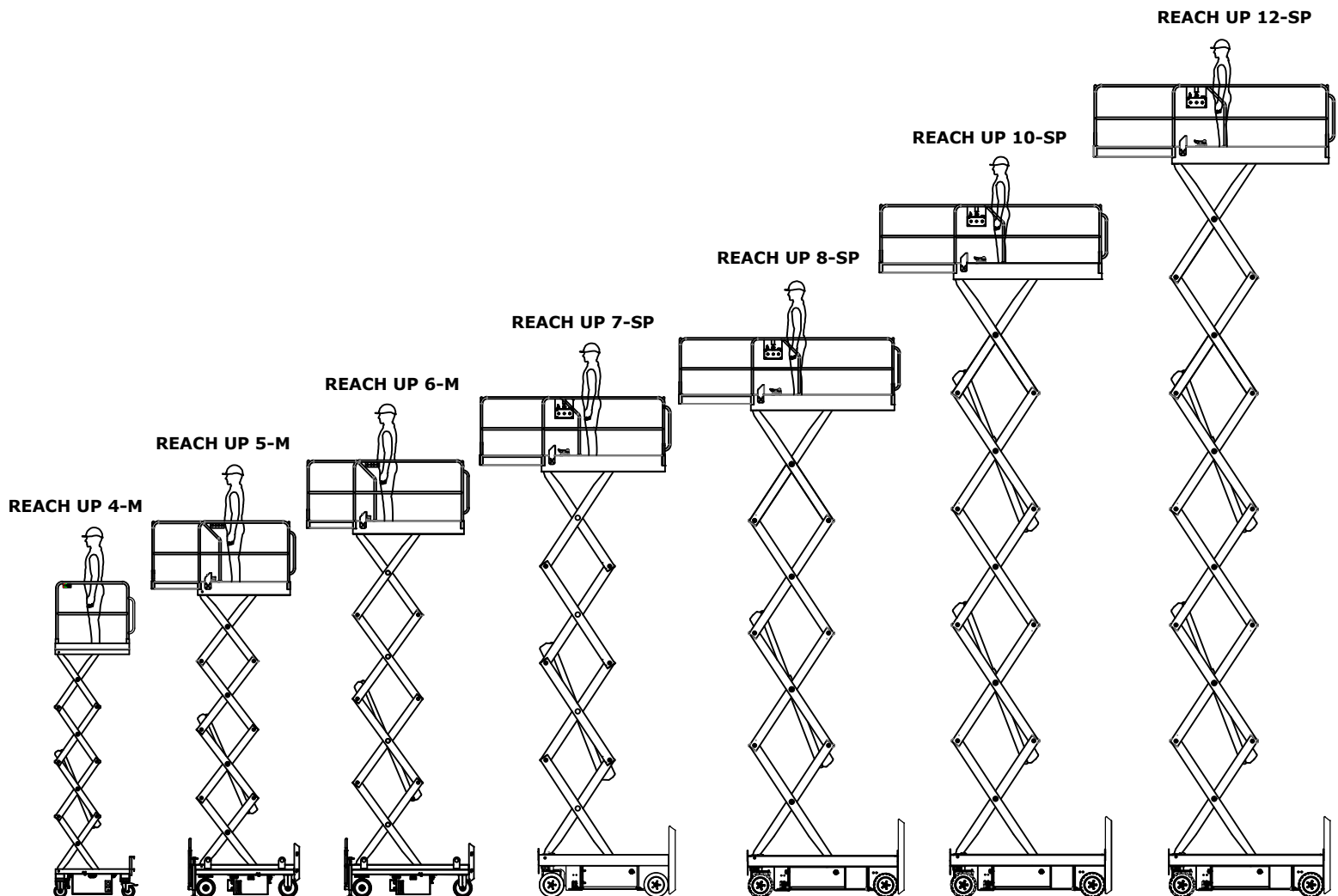

Note: Reach Up must be on a hard level surface while elevated.

Note: Features & Specification subject to change.

FERRO FOUNDRIES PVT LTD.,

Yelwal Road, Belvadi P.O, Mysore 570018 INDIA.

Tel : +91 821 4254605 | WhatsApp: +91 9945820878 | Email : sales@ferrotiger.com | www.ferrotiger.com

TECHNICAL DATA

Working height	6m
Platform height	4m
Lift capacity	200kg
A Platform length outside	1.2m
Platform width outside	0.6m
B Overall width	0.7m
C Stowed height	2.0m
D Overall height	2.0m
E Overall length	1.35m
F Wheel base	1.1m
G Ground clearance center	50cm
Raise / Lower time	18 / 15sec
Turning radius outside	1.5m
Guard rail height	1.1m
PU non marking wheels	20x5cm
Deep cycle traction Batteries	12V-200Ah
DC motor	1.9kw-12VDC
Hydraulic pump	1.2cc
Hydraulic system capacity	6L
Load / wheel	200kg
Equipment weight	800kgs

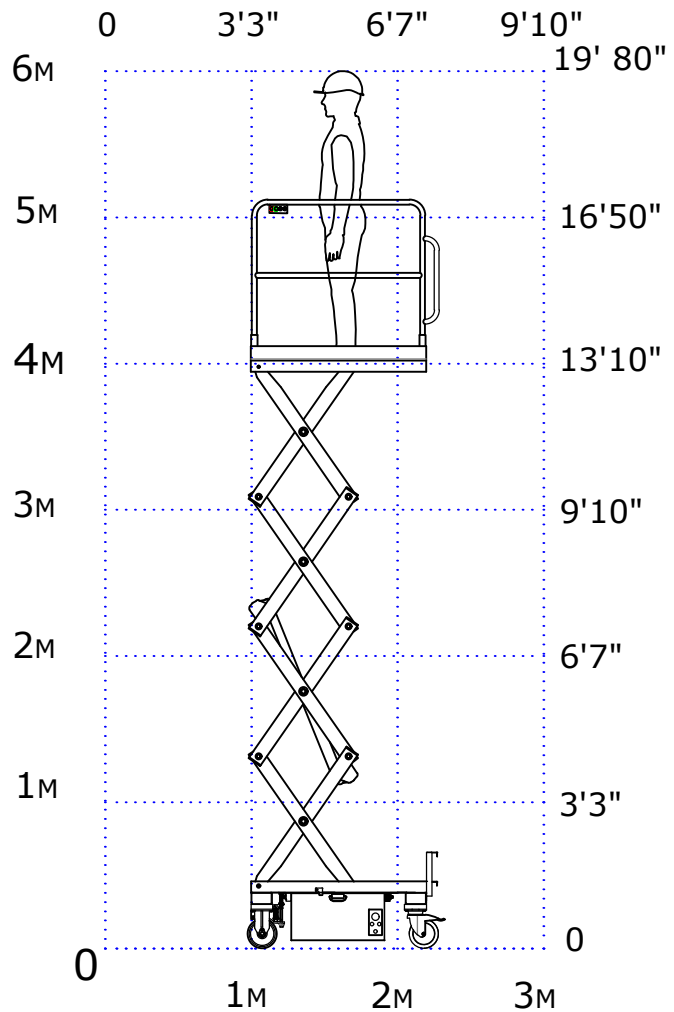

Standard accessories

- Battery charger indicator
- Battery charger
- Lifting hooks
- Push button controls
- Flash light with beeper
- Tilt sensor
- Forklift pocket
- Self engage auto brake
- Manual platform lowering valve
- Emergency stop at both platforms
- Self closing spring gate

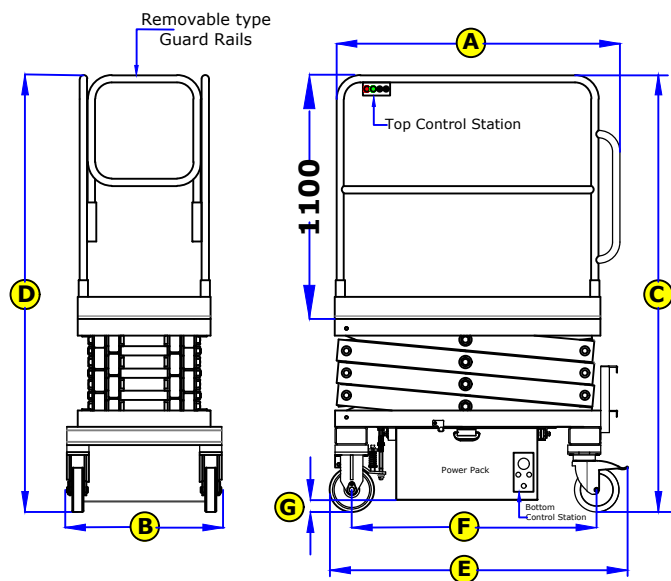

Note: Reach Up must be on a hard level surface while elevated.

Note: Features & Specification subject to change.

FERRO FOUNDRIES PVT LTD.,

Yelwal Road, Belvadi P.O, Mysore 570018 INDIA.

Tel : +91 821 4254605 | WhatsApp: +91 9945820878 | Email : sales@ferrotiger.com | www.ferrotiger.com

TECHNICAL DATA

Working height	7m
Platform height	5m
Lift capacity	300kg
A Platform length outside	1.5m
Platform Length extended	2.25m
Roll out extension	0.75m
Load on roll out platform	150kg
Platform width outside	0.8m
B Overall width	0.8m
C Stowed height	2.2m
D Overall height	2.2m
E Overall length	1.8m
F Wheel base	1.3m
G Ground clearance center	50cm
H Top Platform extended length	2.35m
Raise / Lower time	30 / 25sec
Turning radius outside	2.2m
Guard rail height	1.1m
PU non marking wheels	30x6.5cm
Deep cycle traction Batteries	24V-200Ah
DC motor	2.2kw-24VDC
Hydraulic pump	2.5cc
Hydraulic system capacity	14L
Load / wheel	300kg
Equipment weight	1200kgs

Standard accessories

- Battery charger indicator
- Battery charger
- Lifting hooks
- Push button stations
- Flash light with beeper
- Tilt sensor
- Forklift pocket
- AC power socket top platform
- Manual platform lowering valve
- Emergency stop at both platforms
- Self closing spring gate

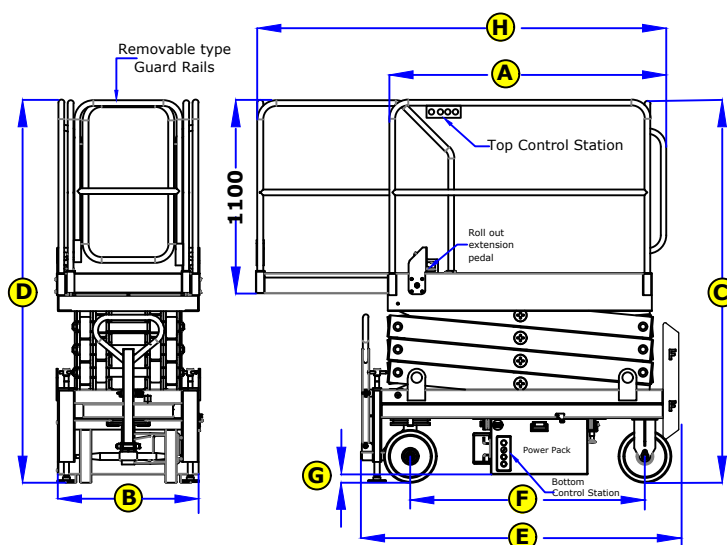
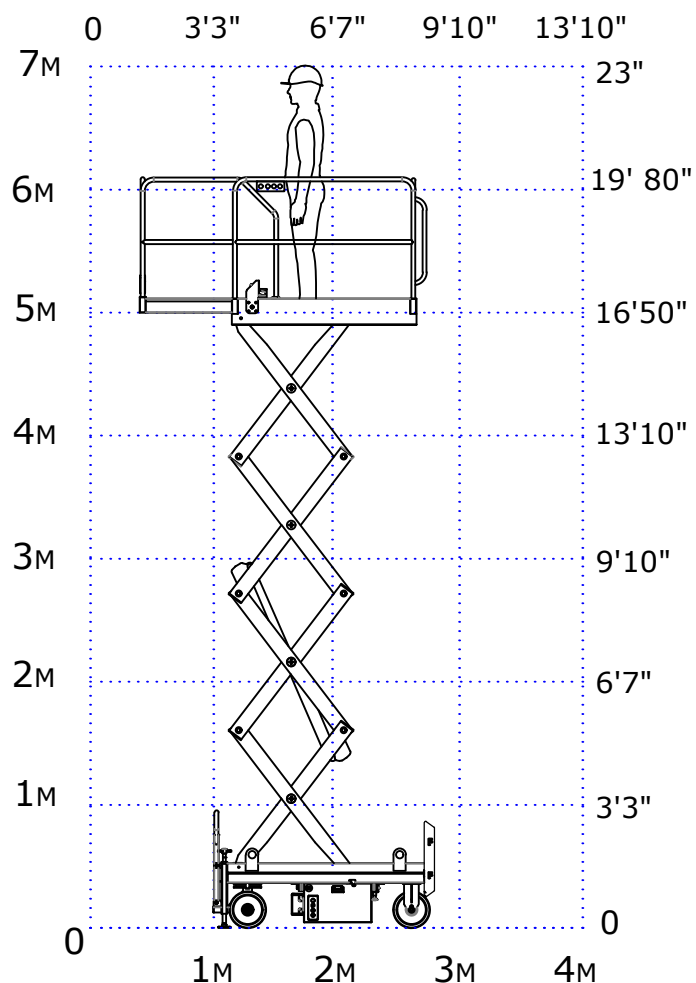

Note: Reach Up must be on a hard level surface while elevated.

Note: Features & Specification subject to change.

FERRO FOUNDRIES PVT LTD.,

Yelwal Road, Belvadi P.O, Mysore 570018 INDIA.

Tel : +91 821 4254605 | WhatsApp: +91 9945820878 | Email : sales@ferrotiger.com | www.ferrotiger.com

TECHNICAL DATA

Working height	8m
Platform height	6m
Lift capacity	300kg
A Platform length outside	1.8m
Platform Length extended	2.7m
Roll out extension	0.9m
Load on roll out platform	150kg
Platform width outside	0.8m
B Overall width	0.8m
C Stowed height	2.2m
D Overall height	2.2m
E Overall length	2.16m
F Wheel base	1.6m
G Ground clearance center	50cm
H Top Platform extended length	2.8m
Raise / Lower time	35 / 30sec
Turning radius outside	2.5m
Guard rail height	1.1m
PU non marking wheels	30x6.5cm
Deep cycle traction Batteries	24V-200Ah
DC motor	2.2kw-24VDC
Hydraulic pump	2.5cc
Hydraulic system capacity	14L
Load / wheel	350kg
Equipment weight	1400kgs

Standard accessories

- Battery charger indicator
- Battery charger
- Lifting hooks
- Push button stations
- Flash light with beeper
- Tilt sensor
- Forklift pocket
- AC power socket top platform
- Manual platform lowering valve
- Emergency stop at both platforms
- Self closing spring gate

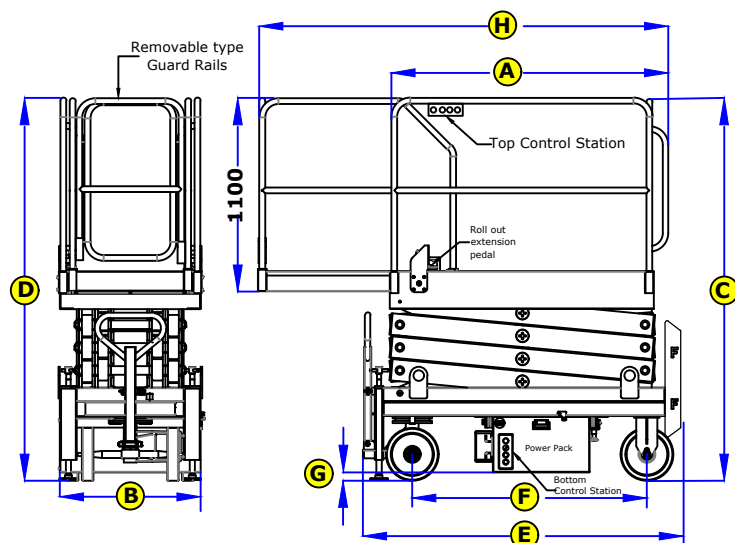
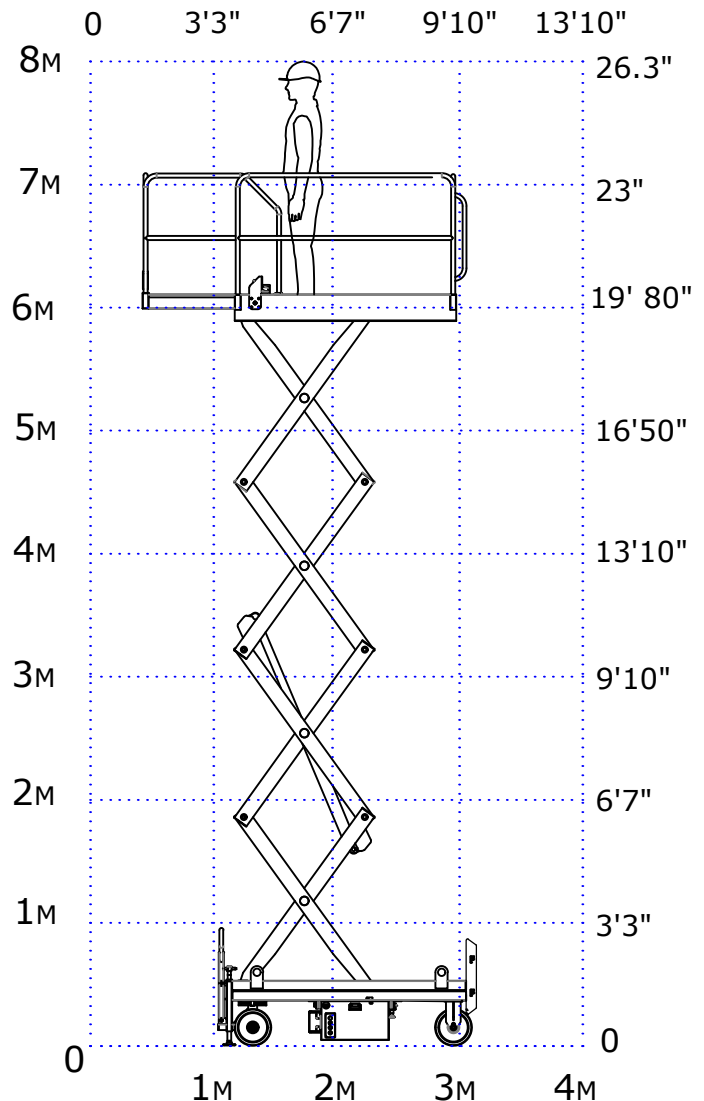

Note: Reach Up must be on a hard level surface while elevated.

Note: Features & Specification subject to change.

FERRO FOUNDRIES PVT LTD.,

Yelwal Road, Belvadi P.O, Mysore 570018 INDIA.

Tel : +91 821 4254605 | WhatsApp: +91 9945820878 | Email : sales@ferrotiger.com | www.ferrotiger.com

TECHNICAL DATA

Platform height.....	5M
Working height.....	7M
Lift capacity.....	400kg
A Platform length outside.....	2m
Platform length extended.....	3m
Roll out extension.....	1m
Load on roll out platform.....	150kg
Platform width outside.....	1m
B Overall width.....	1m
C Stowed height.....	2.35m
D Overall height.....	2.35m
E Overall length.....	2.2m
F Wheel base.....	1.7m
G Ground clearance center.....	11cm
H Top Platform extended length.....	3.1m
Ground Clearance with pothole.....	2cm
Protection deployed	
Drive speed.....	2km/hr
Tilt width / length.....	1.5°/2°
Raise / Lower time.....	30 / 30sec
Turning radius outside.....	1.85m
Guard rail height.....	1.1m
Solid non marking tyres.....	40x12.5cm
Deep cycle traction batteries.....	24V-200AH
DC motor.....	3KW-24VDC
Hydraulic pump.....	3.2 cc
Hydraulic system capacity.....	30L
Load / wheel.....	675kg
Equipment weight.....	2600kg

Standard Features

- Dual front hydraulic drive
- Dual rear hydraulic brakes
- Battery charge indicator
- Battery charger
- Lifting hooks
- Flash light with beeper
- Platform lowering valve
- Pot hole protection device
- Forklift pocket
- AC power socket
- Dual axis tilt sensor with audible alarm
- Emergency stop on both platforms
- Self closing spring entry gate
- Joy stick control
- Folding guard rails with full height swing gate
- On board diagnostic systems
- Lanyard attachment points
- Manual brake release
- Maintenance free batteries
- Motion alarm
- Automobile style horn
- Digital hour meter
- Human machine interference(HMI)
- Drive speed interlock
- Non skid deck(top platform)
- Scissor lift maintenance prop

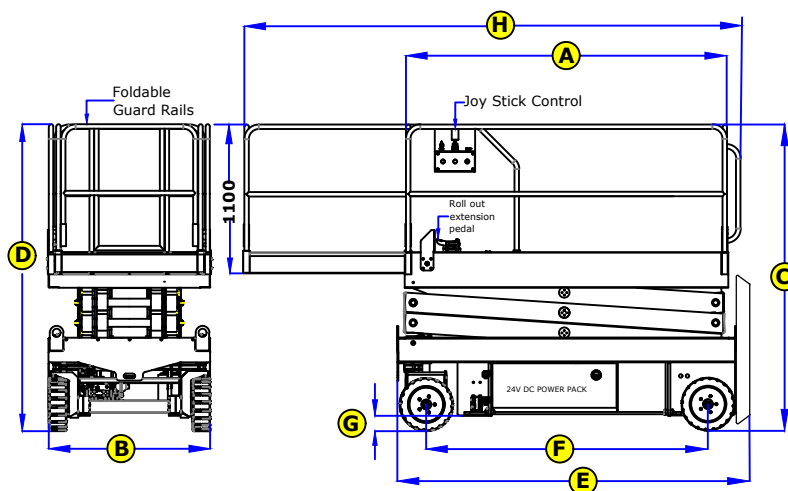
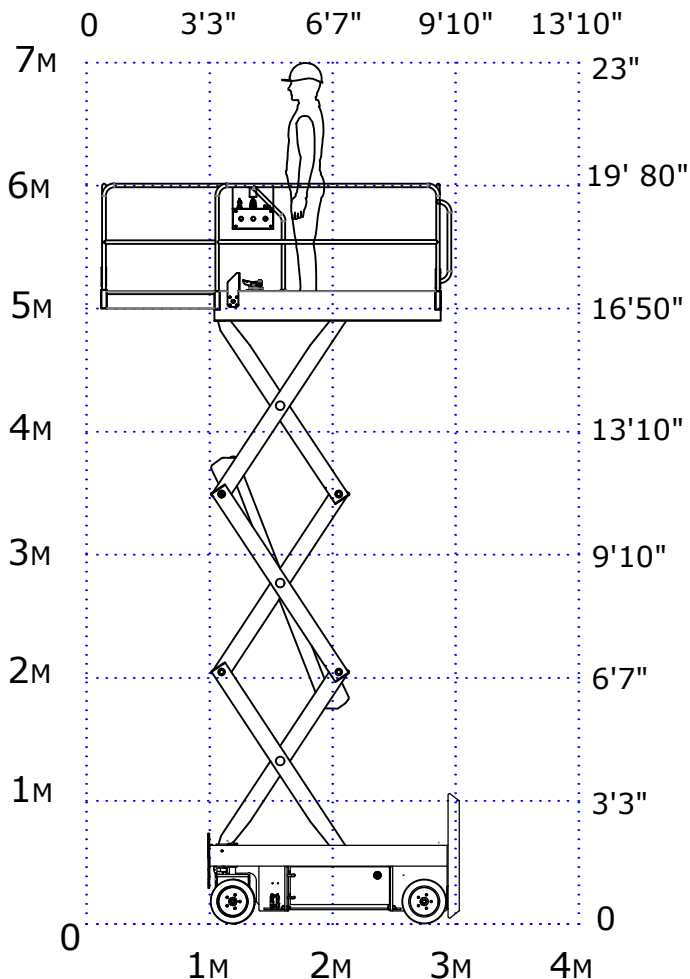

Note: Reach Up must be on a hard level surface while elevated.

Note: Features & Specification subject to change.

FERRO FOUNDRIES PVT LTD.,

Yelwal Road, Belvadi P.O, Mysore 570018 INDIA.

Tel : +91 821 4254605 | WhatsApp: +91 9945820878 | Email : sales@ferrotiger.com | www.ferrotiger.com

TECHNICAL DATA

Platform height.....	7M
Working height.....	9M
Lift capacity.....	300kg
A Platform length outside.....	2m
Platform length extended.....	3m
Roll out extension.....	1m
Load on roll out platform.....	150kg
Platform width outside.....	1m
B Overall width.....	1m
C Stowed height.....	2.5m
D Overall height.....	2.5m
E Overall length.....	2.2m
F Wheel base.....	1.7m
G Ground clearance center.....	11cm
H Top Platform extended length.....	3.1m
Ground Clearance with pothole.....	2cm
Protection deployed	
Drive speed.....	2km/hr
Tilt width / length.....	1.5°/2°
Raise / Lower time.....	35 / 45sec
Turning radius outside.....	1.85m
Guard rail height.....	1.1m
Solid non marking tyres.....	40x12.5cm
Deep cycle traction batteries.....	24V-200AH
DC motor.....	3KW-24VDC
Hydraulic pump.....	3.2 cc
Hydraulic system capacity.....	30L
Load / wheel.....	700kg
Equipment weight.....	2800kg

Standard Features

- Dual front hydraulic drive
- Dual rear hydraulic brakes
- Battery charge indicator
- Battery charger
- Lifting hooks
- Flash light with beeper
- Platform lowering valve
- Pot hole protection device
- Forklift pocket
- AC power socket
- Dual axis tilt sensor with audible alarm
- Emergency stop on both platforms
- Self closing spring entry gate
- Joy stick control
- Folding guard rails with full height swing gate
- On board diagnostic systems
- Lanyard attachment points
- Manual brake release
- Maintenance free batteries
- Motion alarm
- Automobile style horn
- Digital hour meter
- Human machine interference(HMI)
- Drive speed interlock
- Non skid deck(top platform)
- Scissor lift maintenance prop

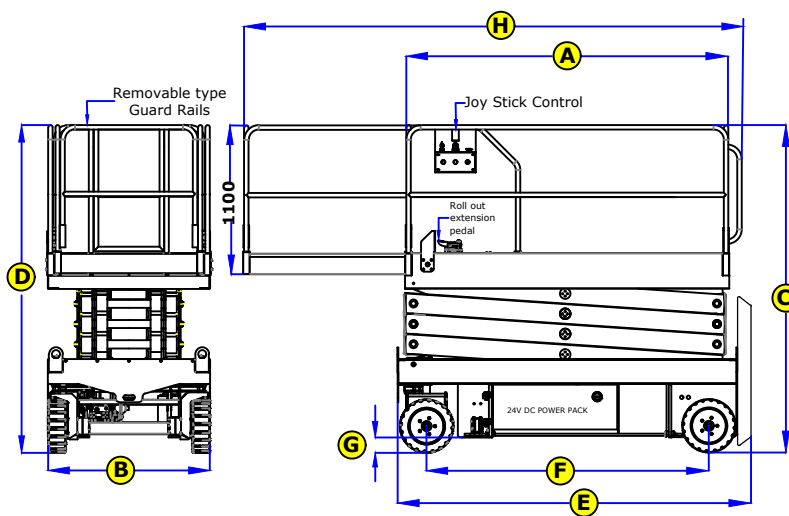
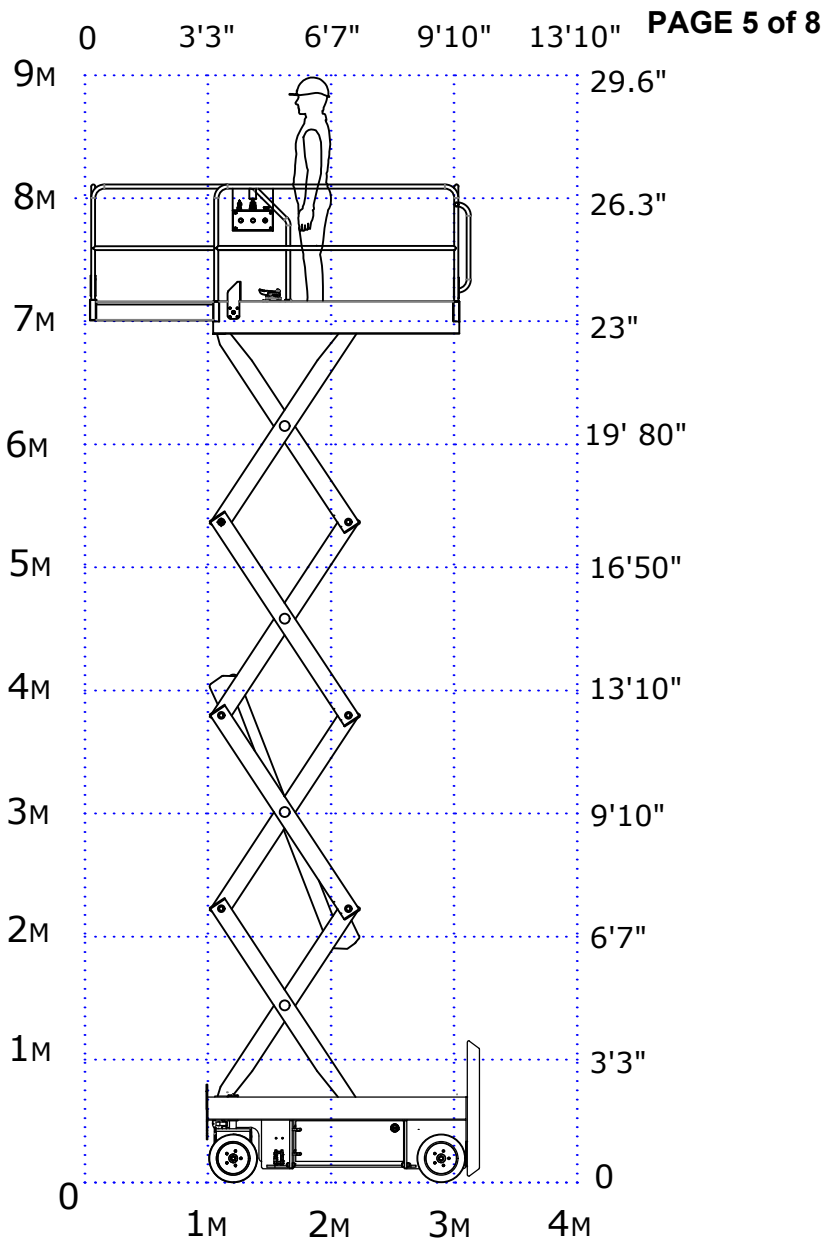

Note: Reach Up must be on a hard level surface while elevated.

Note: Features & Specification subject to change.

FERRO FOUNDRIES PVT LTD.,

Yelwal Road, Belvadi P.O, Mysore 570018 INDIA.

Tel : +91 821 4254605 | WhatsApp: +91 9945820878 | Email : sales@ferrotiger.com | www.ferrotiger.com

TECHNICAL DATA

Platform height.....	8M
Working height.....	10M
Lift capacity.....	300kg
A Platform length outside.....	2.4m
Platform length extended.....	3.6m
Roll out extension.....	1.2m
Load on roll out platform.....	150kg
Platform width outside.....	1.2m
B Overall width.....	1.2m
C Stowed height.....	2.5m
D Overall height.....	2.5m
E Overall length.....	2.6m
F Wheel base.....	2.1m
G Ground clearance center.....	11cm
H Top Platform extended length.....	3.6m
Ground Clearance with pothole.....	2cm
Protection deployed	
Drive speed.....	1.8km/hr
Tilt width / length.....	1.5°/2°
Raise / Lower time.....	75 / 75sec
Turning radius outside.....	2.25m
Guard rail height.....	1.1m
Solid non marking tyres.....	40x12.5cm
Deep cycle traction batteries.....	24V-200AH
DC motor.....	3KW-24VDC
Hydraulic pump.....	3.2 cc
Hydraulic system capacity.....	45L
Load / wheel.....	825kg
Equipment weight.....	3300kg

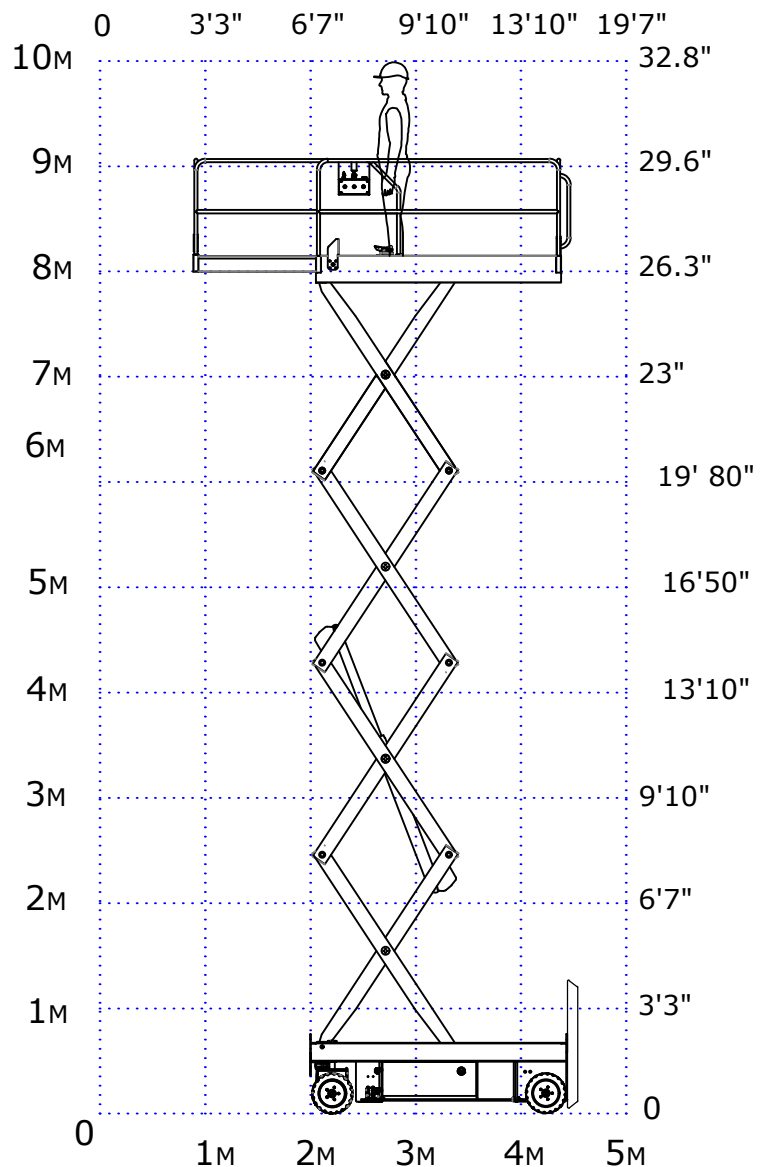

Standard Features

- Dual front hydraulic drive
- Dual rear hydraulic brakes
- Battery charge indicator
- Battery charger
- Lifting hooks
- Flash light with beeper
- Platform lowering valve
- Pot hole protection device
- Forklift pocket
- AC power socket
- Dual axis tilt sensor with audible alarm
- Emergency stop on both platforms
- Self closing spring entry gate
- Joy stick control
- Folding guard rails with full height swing gate
- On board diagnostic systems
- Lanyard attachment points
- Manual brake release
- Maintenance free batteries
- Motion alarm
- Automobile style horn
- Digital hour meter
- Human machine interference(HMI)
- Drive speed interlock
- Non skid deck(top platform)
- Scissor lift maintenance prop

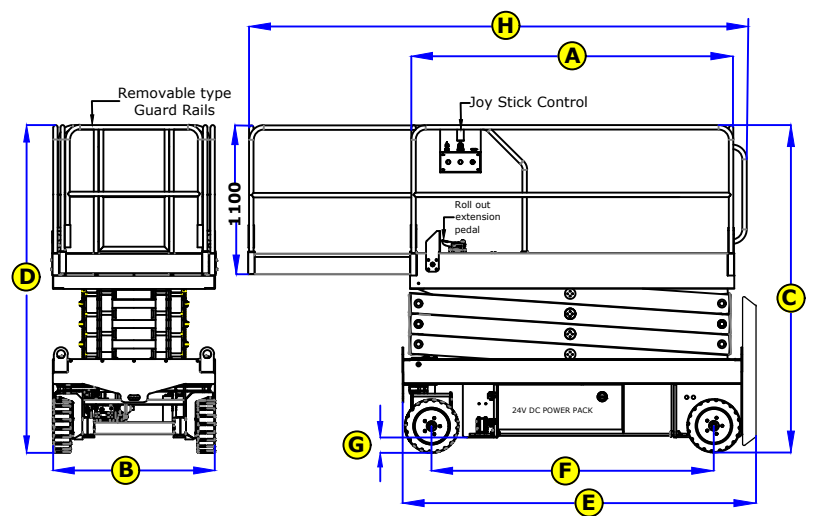

Note: Reach Up must be on a hard level surface while elevated.

Note: Features & Specification subject to change.

FERRO FOUNDRIES PVT LTD.,

Yelwal Road, Belvadi P.O, Mysore 570018 INDIA.

Tel : +91 821 4254605 | WhatsApp: +91 9945820878 | Email : sales@ferrotiger.com | www.ferrotiger.com

TECHNICAL DATA

Platform height.....	10M
Working height.....	12M
Lift capacity.....	300kg
A Platform length outside.....	2.4m
Platform length extended.....	3.6m
Roll out extension.....	1.2m
Load on roll out platform.....	150kg
Platform width outside.....	1.2m
B Overall width.....	1.2m
C Stowed height.....	2.65m
D Overall height.....	2.65m
E Overall length.....	2.6m
F Wheel base.....	2.1m
G Ground clearance center.....	11cm
H Top Platform extended length.....	3.6m
Ground Clearance with pothole.....	2cm
Protection deployed	
Drive speed.....	1.8km/hr
Tilt width / length.....	1.5°/2°
Raise / Lower time.....	90 / 90sec
Turning radius outside.....	2.25m
Guard rail height.....	1.1m
Solid non marking tyres.....	40x12.5cm
Deep cycle traction batteries.....	24V-200AH
DC motor.....	3KW-24VDC
Hydraulic pump.....	3.2 cc
Hydraulic system capacity.....	45L
Load / wheel.....	912kg
Equipment weight.....	3650kg

Standard Features

- Dual front hydraulic drive
- Dual rear hydraulic brakes
- Battery charge indicator
- Battery charger
- Lifting hooks
- Flash light with beeper
- Platform lowering valve
- Pot hole protection device
- Forklift pocket
- AC power socket
- Dual axis tilt sensor with audible alarm
- Emergency stop on both platforms
- Self closing spring entry gate
- Joy stick control
- Folding guard rails with full height swing gate
- On board diagnostic systems
- Lanyard attachment points
- Manual brake release
- Maintenance free batteries
- Motion alarm
- Automobile style horn
- Digital hour meter
- Human machine interference(HMI)
- Drive speed interlock
- Non skid deck(top platform)
- Scissor lift maintenance prop

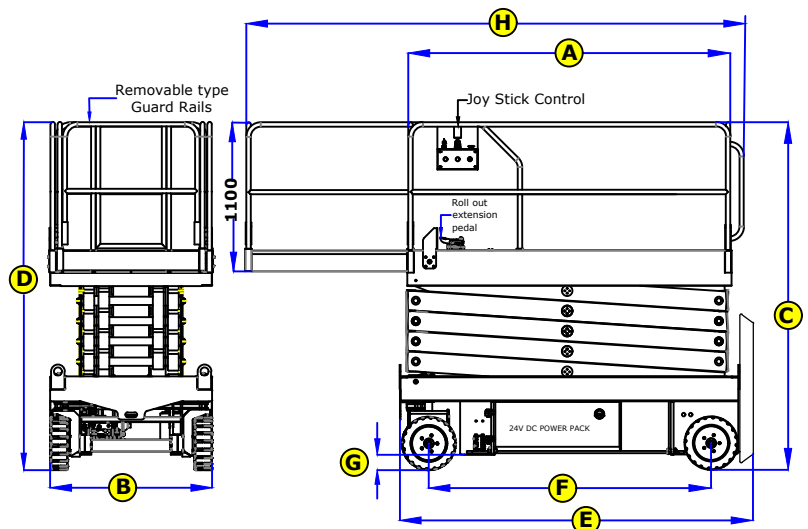
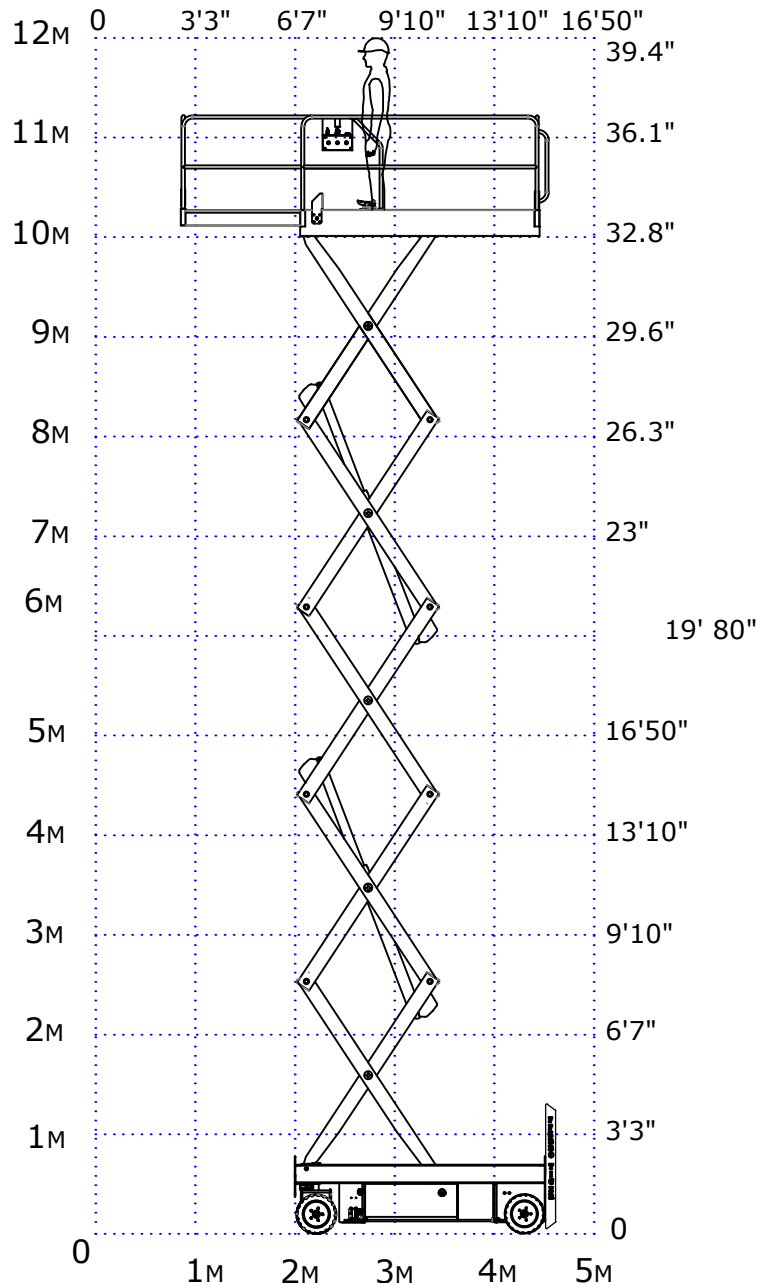

Note: Reach Up must be on a hard level surface while elevated.

Note: Features & Specification subject to change.

FERRO FOUNDRIES PVT LTD.,

Yelwal Road, Belvadi P.O, Mysore 570018 INDIA.

Tel : +91 821 4254605 | WhatsApp: +91 9945820878 | Email : sales@ferrotiger.com | www.ferrotiger.com

TECHNICAL DATA

Platform height.....	12M
Working height.....	14M
Lift capacity.....	300kg
A Platform length outside.....	2.4m
Platform length extended.....	3.6m
Roll out extension.....	1.2m
Load on roll out platform.....	150kg
Platform width outside.....	1.2m
B Overall width.....	1.2m
C Stowed height.....	2.65m
D Overall height.....	2.8m
E Overall length.....	2.6m
F Wheel base.....	2.1m
G Ground clearance center.....	11cm
H Top Platform extended length.....	3.6m
Ground Clearance with pothole.....	2cm
Protection deployed	
Drive speed.....	1.8km/hr
Tilt width / length.....	1.5°/2°
Raise / Lower time.....	110 / 110sec
Turning radius outside.....	2.25m
Guard rail height.....	1.1m
Solid non marking tyres.....	40x12.5cm
Deep cycle traction batteries.....	24V-200AH
DC motor.....	3KW-24VDC
Hydraulic pump.....	3.2 cc
Hydraulic system capacity.....	45L
Load / wheel.....	962kg
Equipment weight.....	3850kg

Standard Features

- Dual front hydraulic drive
- Dual rear hydraulic brakes
- Battery charge indicator
- Battery charger
- Lifting hooks
- Flash light with beeper
- Platform lowering valve
- Pot hole protection device
- Forklift pocket
- AC power socket
- Dual axis tilt sensor with audible alarm
- Emergency stop on both platforms
- Self closing spring entry gate
- Joy stick control
- Folding guard rails with full height swing gate
- On board diagnostic systems
- Lanyard attachment points
- Manual brake release
- Maintenance free batteries
- Motion alarm
- Automobile style horn
- Digital hour meter
- Human machine interference(HMI)
- Drive speed interlock
- Non skid deck(top platform)
- Scissor lift maintenance prop

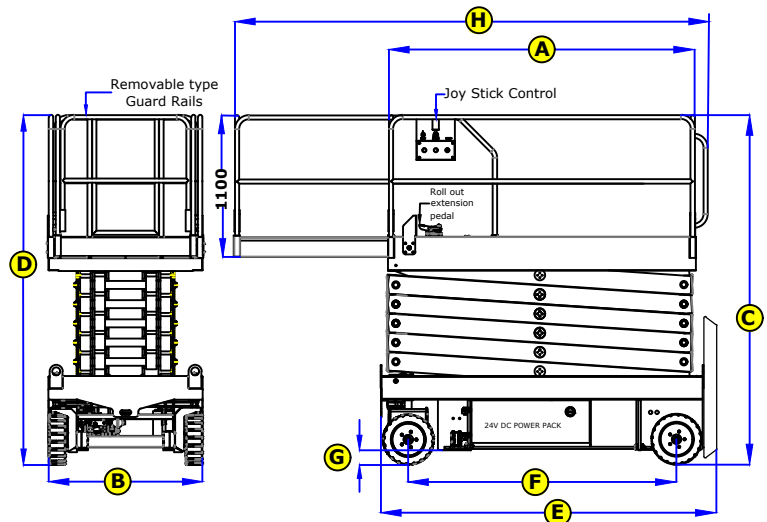
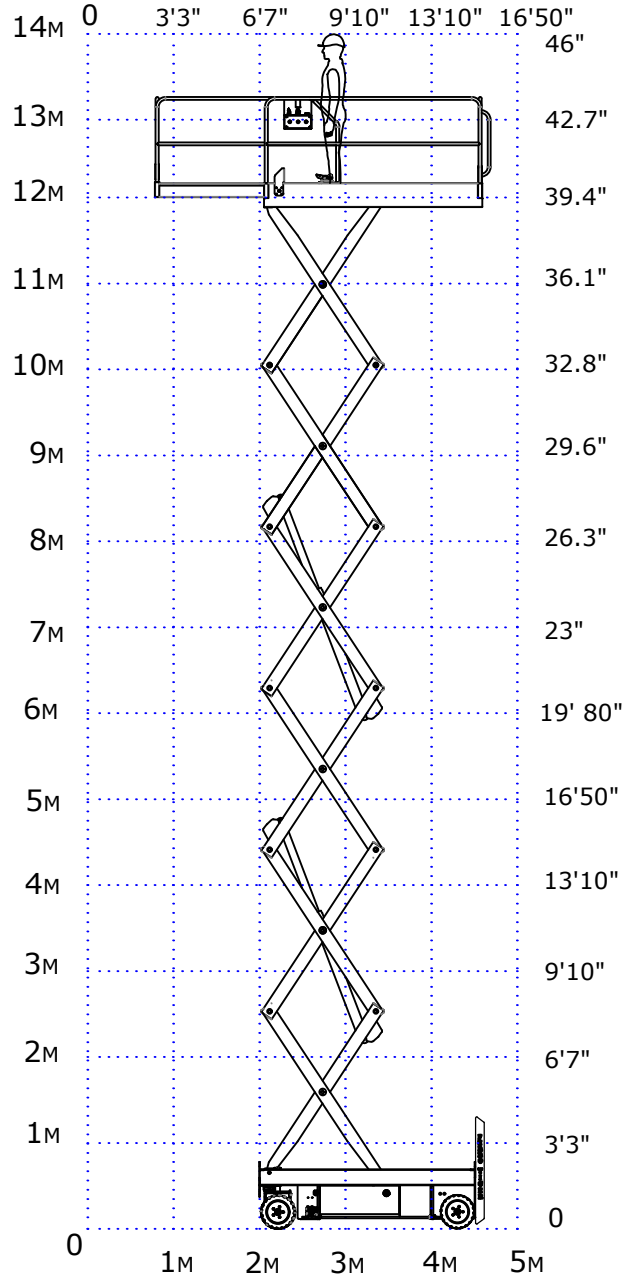

Note: Reach Up must be on a hard level surface while elevated.

Note: Features & Specification subject to change.

FERRO FOUNDRIES PVT LTD.,

Yelwal Road, Belvadi P.O, Mysore 570018 INDIA.

Tel : +91 821 4254605 | WhatsApp: +91 9945820878 | Email : sales@ferrotiger.com | www.ferrotiger.com

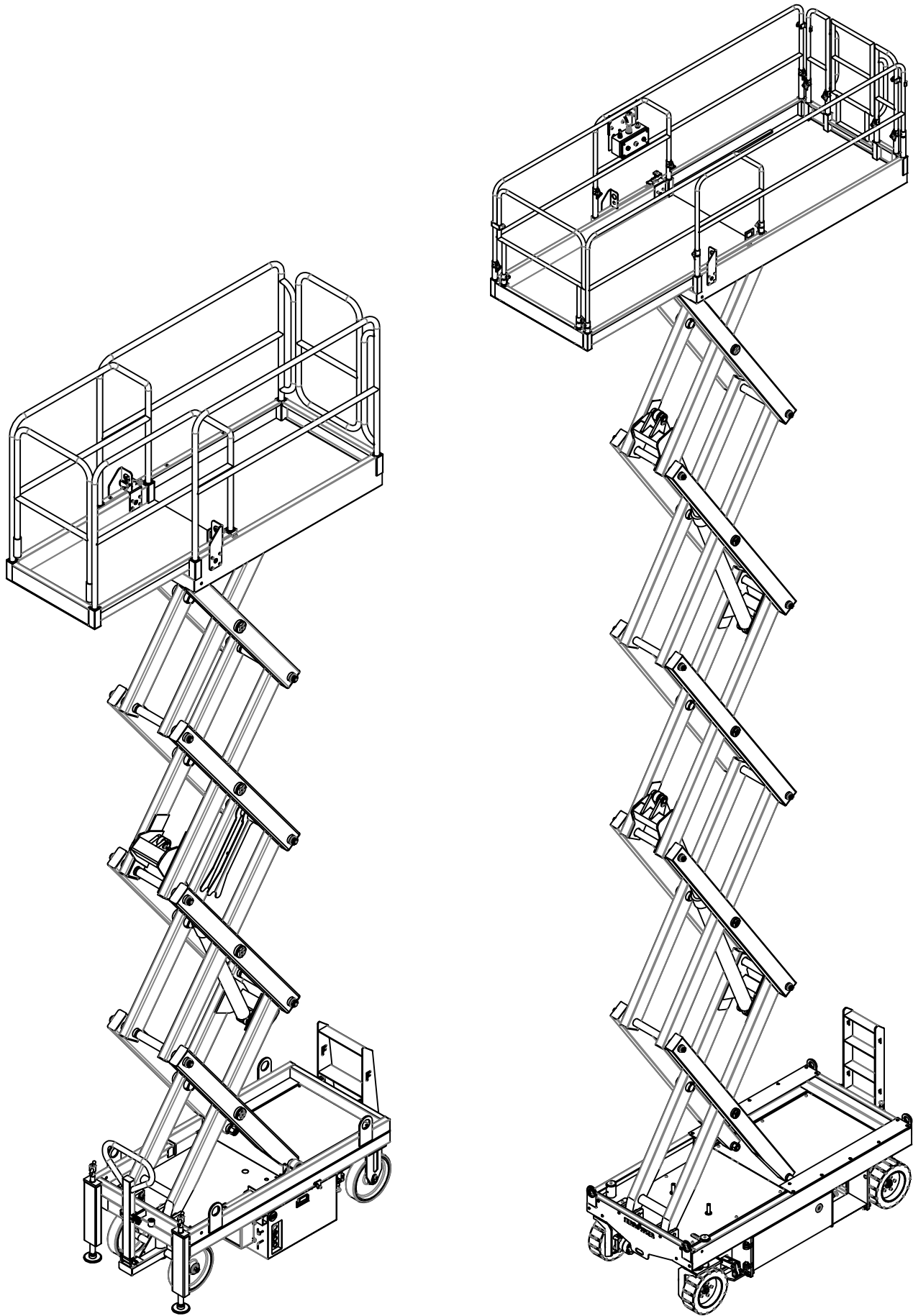

FERRO FOUNDRIES PVT LTD.,

Yelwal Road, Belvadi P.O, Mysore 570018 INDIA.

Tel : +91 821 4254605 | WhatsApp: +91 9945820878 | Email : sales@ferrotiger.com | www.ferrotiger.com



NOTES :

ERGONOMICS FOR THE MODERN FACTORY



- Request us for a Free Factory Audit.



SPECIFICATIONS

- Capacity 250Kgs to 3T.
- Closed Height 90/100mm.
- Max Lift Height 700/900/1200mm.
- NO PIT REQUIRED.
- Can Be Customized.

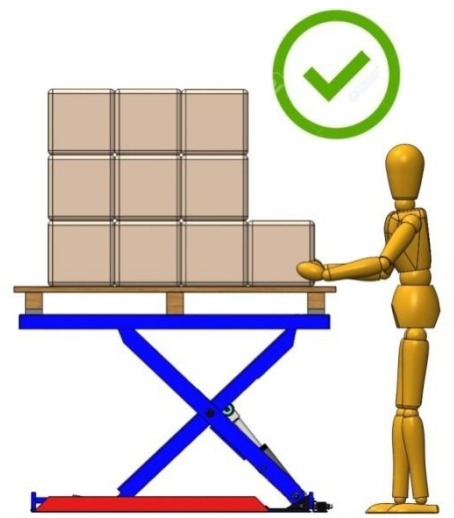

R - PLATFORM SLIM LIFT

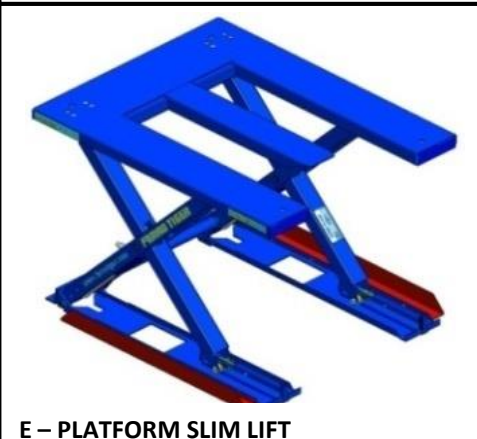

E - PLATFORM SLIM LIFT

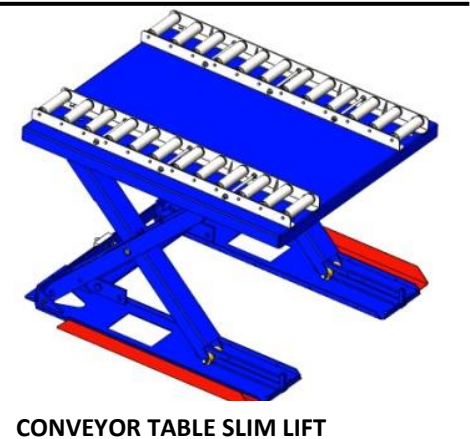

CONVEYOR TABLE SLIM LIFT



ROTARY TABLE SLIM LIFT

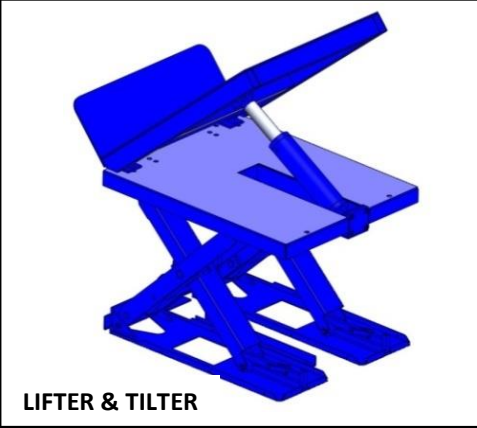

LIFTER & TILTER

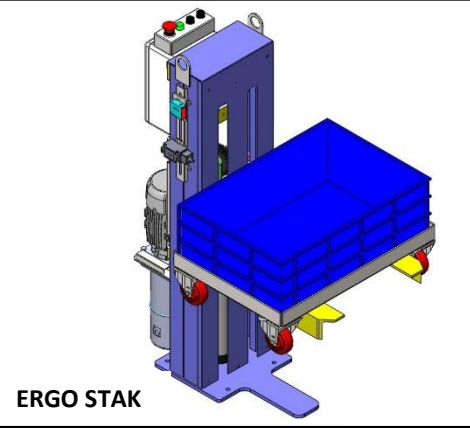

ERGO STAK

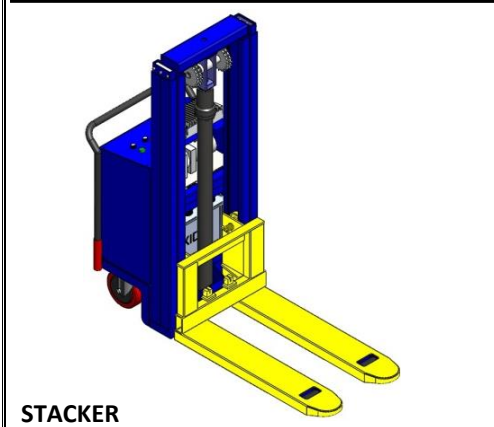

STACKER

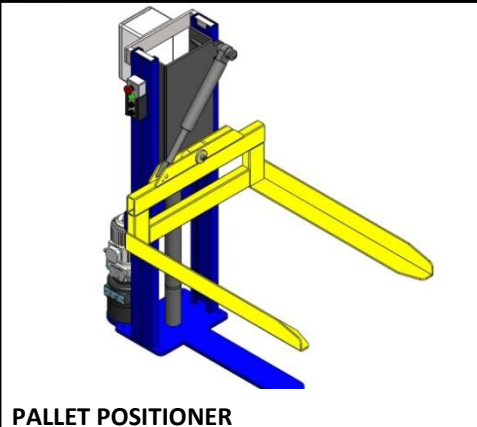

PALLET POSITIONER

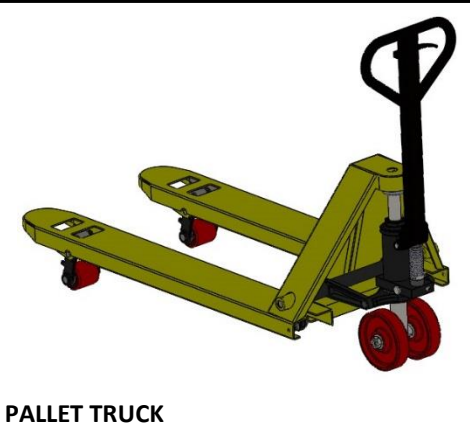

PALLET TRUCK