

TECHNICAL DATA

Platform height	4m
Working height	6m
Lift capacity	100kg
A Platform length outside	1.2m
B Overall width	0.7m
C Stowed height	2.0m
D Overall height	2.0m
E Overall length	1.35m
F Wheel base	1.1m
G Ground clearance center	5cm
H Approach Height	0.48m
I Platform width	0.6m
Raise / Lower time (lift)	30 / 30sec
Raise / Lower time (order picker)	10 / 10sec
Turning radius outside	1.5m
Guard rail height	1.1m
PU non marking wheels	20x5cm
Deep cycle traction Batteries	12V-200Ah
DC motor	1.9kw-12VDC
Hydraulic pump	1.2cc
Hydraulic system capacity	6L
Load / wheel	200kg
Equipment weight	800kgs

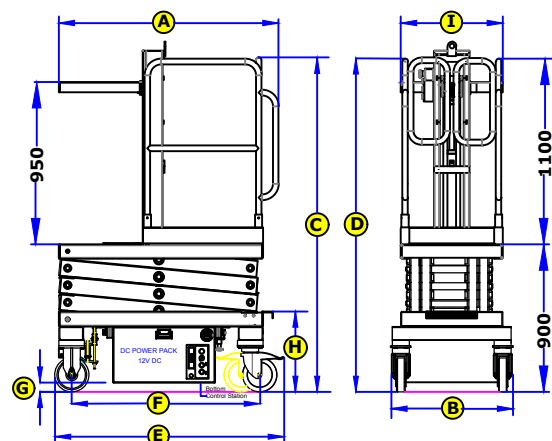
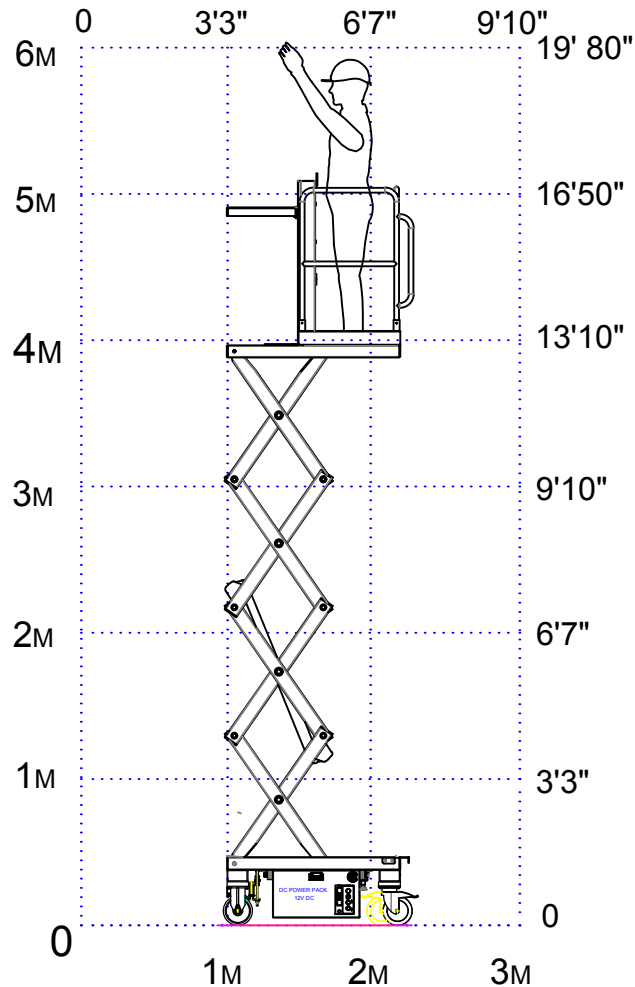

Standard accessories

- Battery charger indicator
- Battery charger
- Lifting hooks
- Push button controls
- Forklift pocket
- Self engage auto brake
- Manual platform lowering valve
- Emergency stop at both platforms
- Self closing spring gate
- Anti-slip marine grade plywood on top platform

Benefits

- Higher productivity can be achieved at full height
- Excellent maneuverability, safe, quick and precise positioning in very congested sites
- Large material tray, non-slip, adjustable in any positions
- It can be pass through standard doorways and carried in passenger elevators
- Ease of loading either by ramps, forklift pockets and crane lifting points
- Light and handy, with non marking tires, ideal for delicate and/or raised access flooring
- Outstanding battery capacity provides long endurance
- Emergency lowering device easy and quick to operate

Note: Equipment must be on a hard level surface while elevated.

Note: Features & Specification subject to change.