



Flexibility, innovation and safety for your work

## COUNTERBALANCED 360° SWIVEL CRANES



A complete range of counterbalanced 360° swivel cranes with manual traction, , with a **maximum capacity up to 500 kg and outreach up to 1300 mm**. Hydraulic lever controlled or electric controlled. They represent the most cost-effective and flexible solution for lifting and transporting loads in several applications such as machining centers and machine tools, delivery to assembly lines, assembly operations, goods handling. Thanks to their compact dimensions they are easily maneuverable even at full load and can be moved effortlessly in confined spaces. All components are made in Italy to ensure the highest construction quality and the absence of defects.

The hydraulic system is equipped with a lock valve that prevents the load from falling in case of accidental breakage of the pipes and a rough valve that prevents overloading of the crane.

They are equipped with 2 high-capacity pivoting wheels with bumper mounts and parking brakes and with 2 fixed front wheels with bearings. The frame is made of painted steel and is equipped at the base with 2 useful forklift supports (to lift and transport the crane in complete safety on long distances). The sturdy push handle can be disassembled. There are also 2 handles to easily rotate the ballast. Swivel hook type. Rotating Jib arm with 8 locking positions.

### CERTIFICATION AND COMPLIANCE WITH REGULATIONS FOR THE PROTECTION AND SAFETY IN THE WORKPLACE

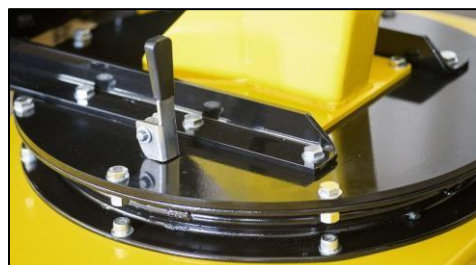
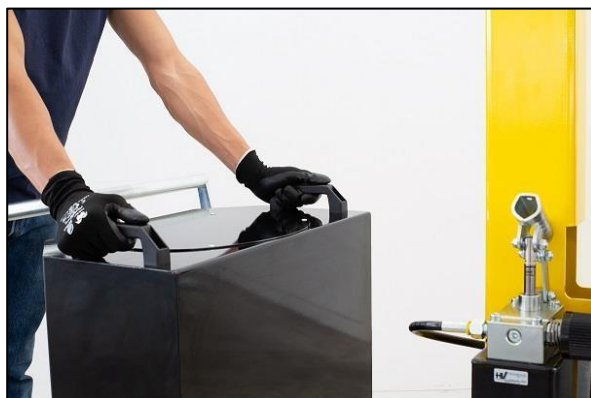

**01B2SE\_400**  
**CAPACITY 200 KG**  
**COUNTERBALANCED SWIVEL CRANE, POWERED LIFT /LOWER & POWERED EXTEND/RETRACT**  
**JIB ARM WITH PROGRESSIVE SPEED**



<b>Technical data</b>	UM	01B2SE_400
Weight	[kg]	445
Max capacity	[kg]	200
Max pressure	[bar]	60
Tank capacity	[Liters]	2,5
Cylinder stroke	[mm]	470

Model 01B2SE\_400 is equipped with an electric controlled jib arm . It is equipped with a 4 way fine control lever controls for :

- Lifting the jib arm
- Lowering the jib arm
- Extending the jib arm
- Retracting the jib arm

All movements (arm and extension) are electric controlled, progressive and adjustable by the operator with extreme precision. Controlled descent system with the engine off.

**Model 01B2SE\_400, being a crane with a maximum capacity of 200 kg, does not require a third-party certification according to current legislation.**

CAPACITY AND DIMENSIONS WITH STANDARD JIB ARM	
Length	Capacity
[mm]	[kg]
from 410 to 810	from 200 to 130

CAPACITY WITH OPTIONAL EXTENDED JIB ARM		
Length	Capacity	
[mm]	[kg]	
from 912 to 1312	from 92 to 71	
1 battery	[V]	12
	[A]	80
Battery charger	[V]	220
	[A]	12

Detail of the 4 way fine control lever



# 01B2SE\_400

## TECHNICAL DRAWINGS, DIMENSIONS AND CAPACITIES

The mini crane with electric controlled extension and a footprint of 800 mm

### STANDARD EXTENSION

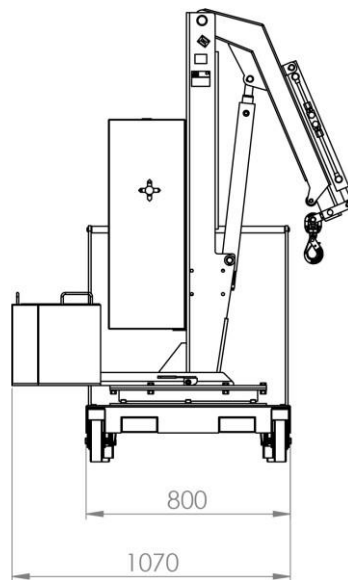
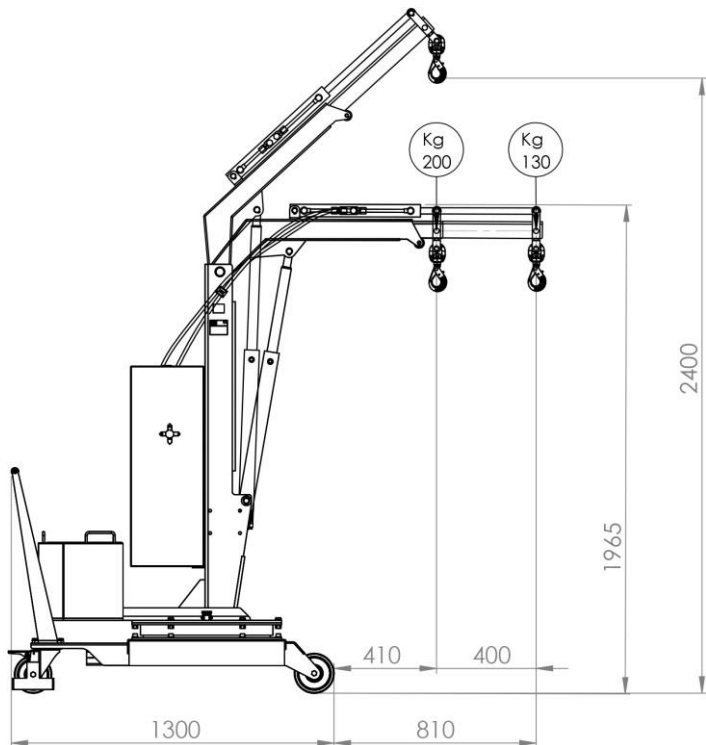

### OPTIONAL EXTENSION

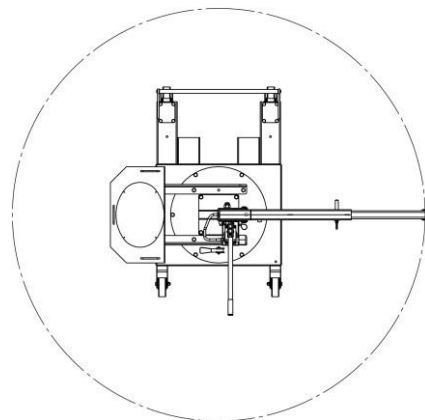
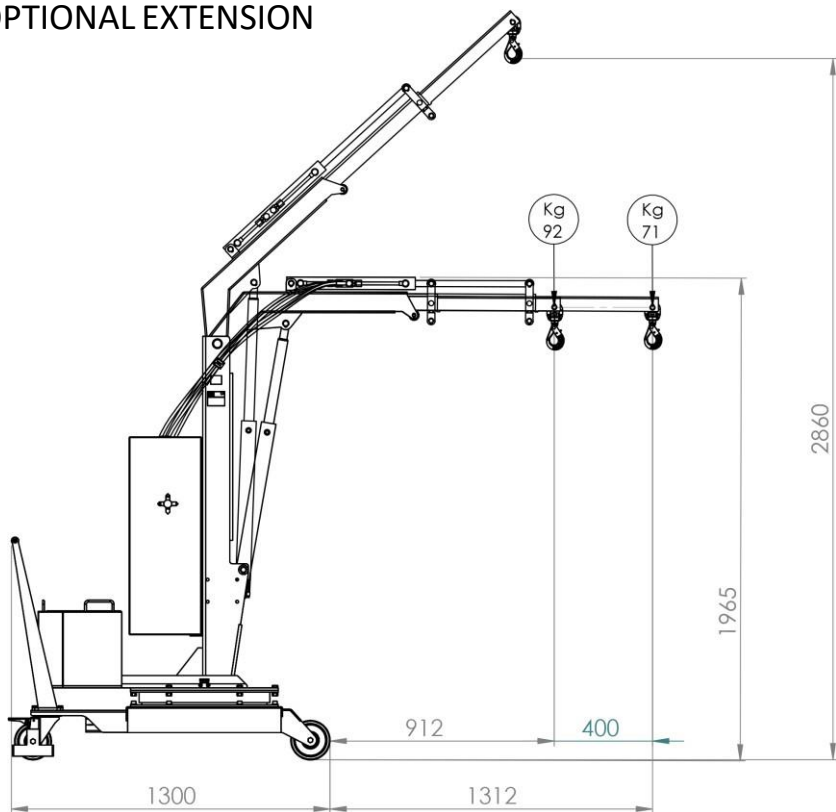

**01B2SE\_400**  
**LOAD CHART**

